

## A1-9

90cm "Opera" Cooker with Multifunction Oven and Gas hob, Stainless Steel & Eclipse Glass  
Energy rating A+

EAN13: 8017709229160



reddot award 2018  
winner

[Red Dot Design Award 2018](#)

### OVEN



- 11 functions
- Oven capacity: gross –126 litres, net -115 litres
- Usable cavity space dimensions (HxWxD): 371x724x418mm
- **50 automatic programmes**
- 10 customisable recipes
- Other functions; defrost by time, defrost by weight, warming, rising
- **Large LCD display**
- **Eclipse black glass**
- Air cooling system
- Closed door grilling
- 5 cooking levels, metal side supports
- Tilting grill
- Easy clean enamel interior
- **Triple fan**
- 2 x lights
- Triple glazed door
- **Soft close door**
- **Vapor clean function**
- Storage compartment drawer

### HOB

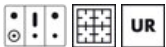

- 6 burners
- Rear left: Rapid 3.0kW
- Front left: **Ultra Rapid 4.2kW**
- Rear centre: 1.8kW
- Front centre: 1.0kW
- Rear right: Rapid 3.0kW
- Front right: 1.8kW
- Heavy duty cast iron pan stands
- Automatic electronic ignition
- Safety valves
- Adaptable for LPG



#### STANDARD ACCESSORIES:

- 2 x Extra deep trays (40mm deep)
- 2 x Chrome shelves
- 1 x Grill mesh
- 1 x Rotisserie
- 1 x Cast iron wok support
- 3 x Stay clean liners
- 1 x Telescopic shelf set (partial extraction)

#### Nominal power: 3.2 kW

- Supply can vary depending on usage, please consult a qualified electrician for ampere requirement

## Functions

---



## Options

---

- KIT1A1-9** - 90cm Stainless Steel Splashback for A1-9 & A1BL-9
- GT1T-2** - Pair of fully extractable telescopic guides
- PPR9** - Rectangle refractory pizza stone without handles
- PALPZ** - Folding Pizza Shovel
- GT1P-2** - Pair of partially extractable telescopic guides
- WOKGHU** - Wok Support
- TPKX** - Teppanyaki Grill Plate



## Main Oven



### Lower heating element only:

Ideal for foods that require extra base temperature without browning, e.g. pastry dishes, pizza. Also suitable for slow cooking of stews and casseroles.

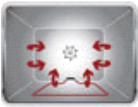

### FAN WITH LOWER ELEMENT/ CIRCOGAS:

In electric ovens this combination completes cooking more quickly of foods that are ready on the surface, but that require more cooking inside, without further browning. In gas ovens the fan distributes the heat quickly and evenly throughout the oven cavity, avoiding flavour transfer when cooking a number of different dishes at the same time.



### Upper and lower element only:

A traditional cooking method best suited for single items located in the centre of the oven. The top of the oven will always be hottest. Ideal for roast, fruit cakes, bread etc.

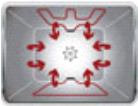

### Fan with upper and lower elements:

The elements combined with the fan aim to provide more uniform heat, a similar method to conventional cooking, so pre-heat is required. Most suitable for items requiring slow cooking methods.



### Circulaire:

The combination of the fan and circular element around it gives a hot air cooking method. This provides many benefits including no preheat if cook time is more than 20 minutes, no flavour transfer when cooking different foods at the same time, less energy, and shorter cook times. Good for all types of food.



### Circulaire with upper and lower elements:

The use of the fan with both elements allows food to be cooked quickly and effectively, ideal for large joints that require thorough cooking. It offers a similar result to rotisserie, moving the heat around the food, instead of moving the food itself, enabling any size or shape to be cooked.



### ECO:

The combination of the grill, fan (if present) and lower element is particularly suitable for cooking small quantities of food.



### Fan with grill element:

The fan reduces the fierce heat from the grill, providing an excellent method of grilling various foods, chops, steaks, sausages etc. giving even browning and heat distribution, without drying out the food. The top two levels recommended for use, and the lower part of the oven can be used to keep items warm at the same time, an excellent facility when cooking a grilled breakfast. Half grill (centre portion only) is ideal for small quantities of food.



### Grill element:

For rapid cooking and browning of foods. Best results can be obtained by using the top shelf for small items, the lower shelves for larger ones, such as chops or sausages. For half grill heat is generated only at the centre of the element, so is ideal for smaller quantities.



### Rotisserie with full grill:

These symbols allow use of the rotisserie with full grill.

**Smeg (UK) Ltd**  
**The Magna Building, Wyndyke Furlong, Abingdon**  
**OX14 1DZ**  
**Tel. +44 (0)844 557 9907**  
**Fax +44 (0)844 557 9337**



A1-9

Opera range  
90 cm  
stainless steel  
hob type: cookers with gas hob  
oven type: electric  
energy rating A+

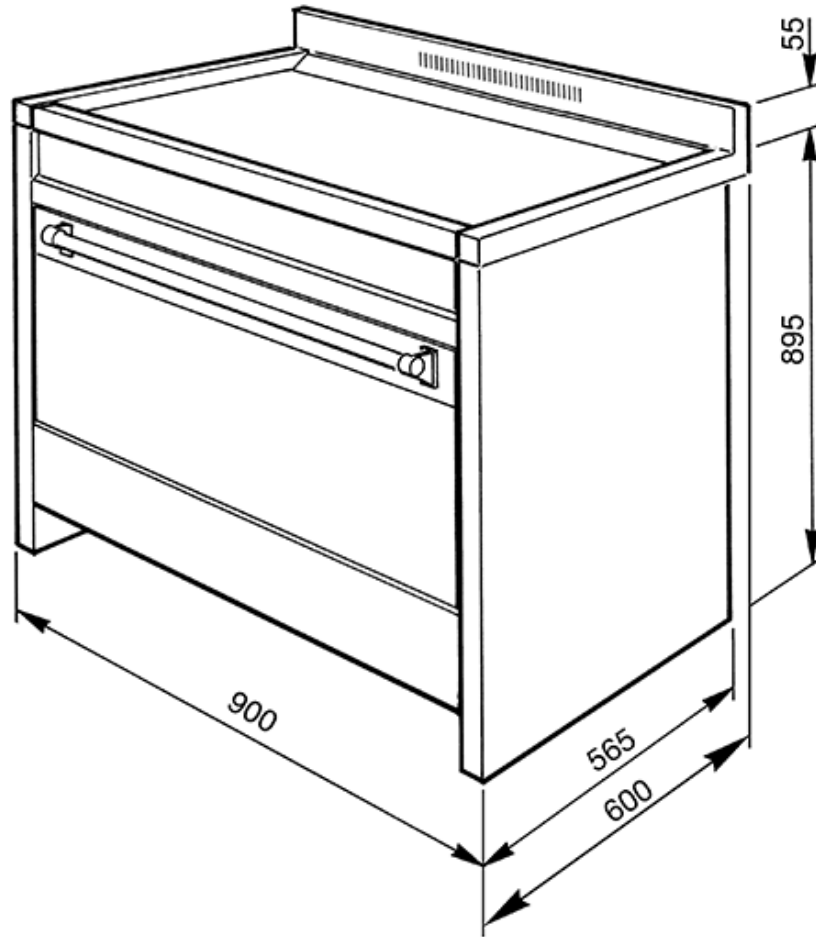

Smeg (UK) Ltd  
The Magna Building, Wyndyke Furlong, Abingdon  
OX14 1DZ  
Tel. +44 (0)844 557 9907  
Fax +44 (0)844 557 9337